

LGH-RVX(T)

LOSSNAY - Heat recovery ventilation unit

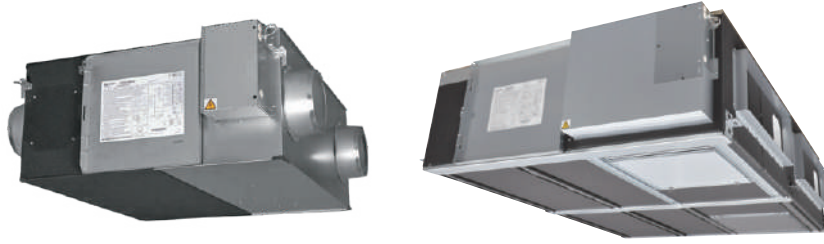

Lossnay – Heat recovery ventilation units

The importance of adequate air exchange

Air quality is a primary parameter for comfort. Poor air quality in the office or at home has been proven to have a significantly detrimental influence on productivity and on the healthiness of the environment, and contribute to fatigue. This is due to increasing concentrations of CO₂ caused by inadequate air exchange. To live comfortably, **every individual needs 400l of fresh air per hour**. Ensuring **adequate ventilation** in residential and commercial buildings is necessary to **offer a healthy, comfortable environment for all occupants**.

A dry environment offers the ideal conditions for the proliferation of **bacteria and viruses**, and the survival rate of these micro-organisms drops rapidly at relative humidity levels above 50%. **Excessively humid environments**, on the other hand, encourage the proliferation of **mould and mites**. Precise humidity control is therefore an important factor in maintaining ideal, healthy conditions.

The importance of correctly controlled humidity

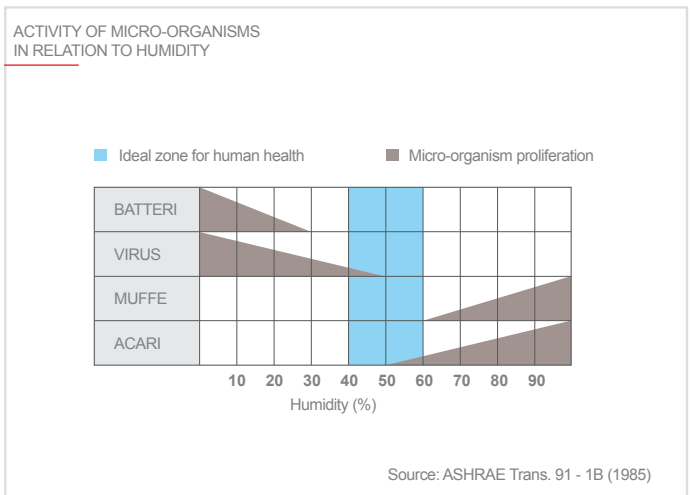
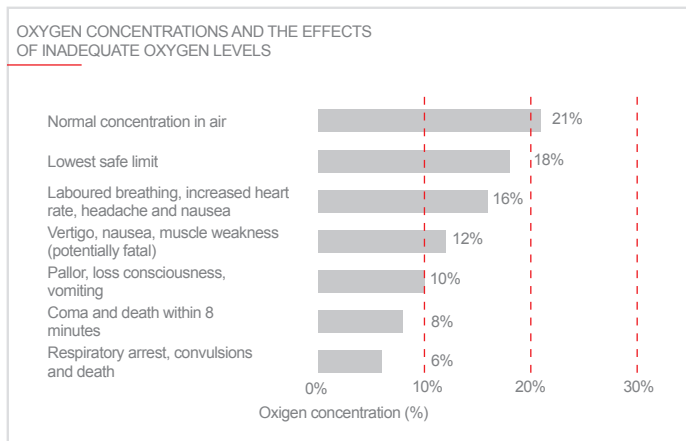

Simple construction

As shown in the figure, the Lossnay exchanger consists of a structure in special treated paper allowing two different air flows to cross one another and exchange thermal energy. Partitions separating the inlet and outlet channels prevent incoming fresh air from ever mixing with outgoing air.

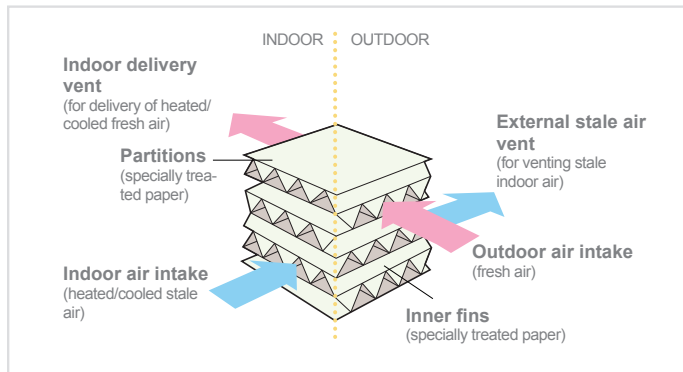

Operating principle

The Lossnay exchanger performs a highly effective total exchange action for both temperature (sensible heat) and humidity (latent heat) – the system uses moisture permeable partitions in specially treated paper to allow stale air to be vented externally and fresh outdoor air to be fed to the indoor space with absolutely no mixing between the two air flows.

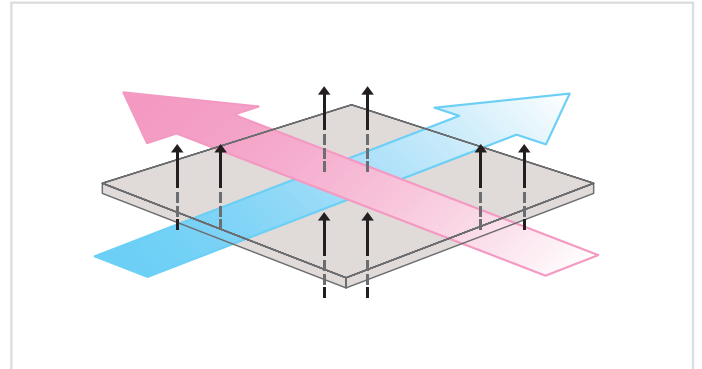

Energy recovery

Comfort and energy savings

With universally recognised efficiency, Lossnay heat exchanger ventilation units use energy recovery to offer significant energy savings.

A conventional ventilation system vents treated indoor air into the outdoor environment and replaces this air with outdoor air, causing the room to lose heat in winter and heat up in summer. This loss of heated/cooled air means that energy must be expended to restore comfortable temperature conditions in the indoor space. The result of this is notably higher air conditioning costs. To solve this problem while still ensuring the necessary air exchange, Mitsubishi Electric offers a range of thermal energy recovery ventilation systems, which minimise air conditioning costs.

All Lossnay units are equipped with class "G3" air filter as standard (Coarse 35% based on ISO 16890). LGH-RVX models may also be equipped with a class "M6" high efficiency filter (ePM10 75% based on ISO 16890).

Comfortable air exchange action, in either cold or hot outdoor conditions

Summer - Difference in temperature between new fresh air and air already in room of only 1.7°C.

- Incoming fresh air is brought to the same conditions as the cooled (and dehumidified) air in the room.

Winter - 4 kg/h humidity recovered

- Incoming fresh air is brought to the same conditions as the warmed (and humidified) air in the room.

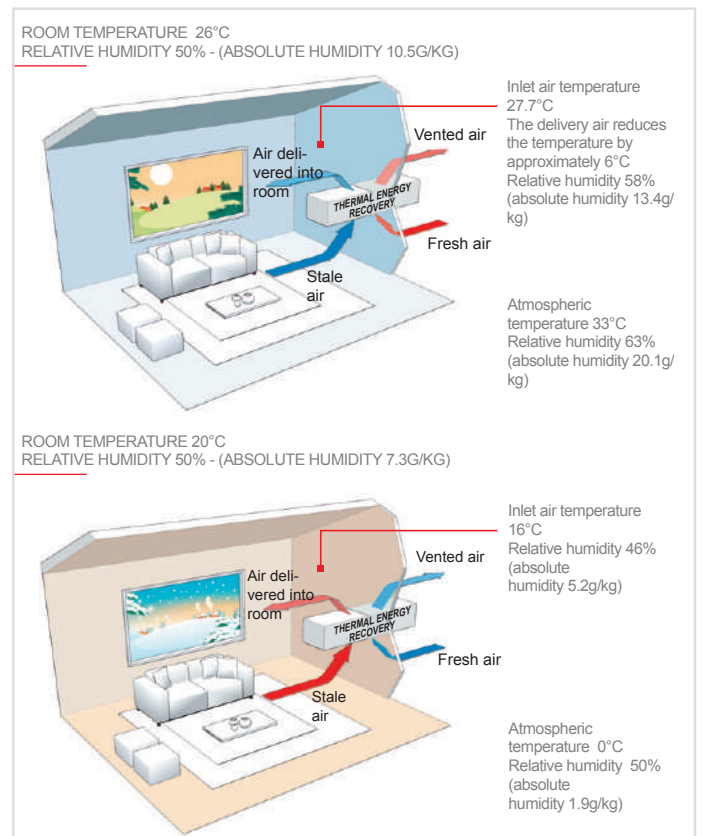
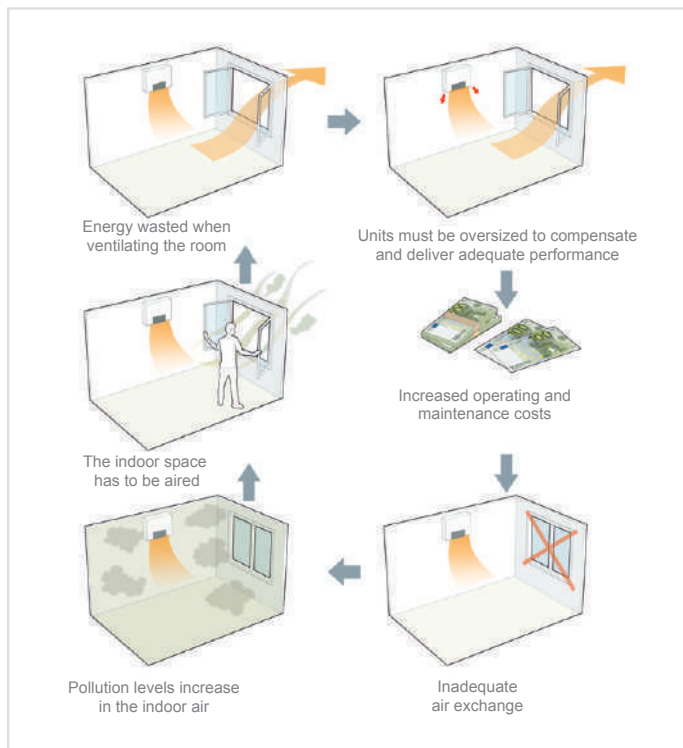

Low noise

Precise control over the flow of treated air significantly reduces the sound pressure values of the LOSSNAY unit by up to 18 dB(A). All LGH-RVX units ensure ideal acoustic comfort, including for residential applications, libraries, offices etc.



Lossnay for energy savings

New DC FAN Motor

The new DC motor used throughout the new LGH-RVX series offers a number of advantages:

- **Very low electric power consumption**, especially at low speeds
- Lower noise emissions
- Increased flexibility and fine air flow adjustment from remote control.

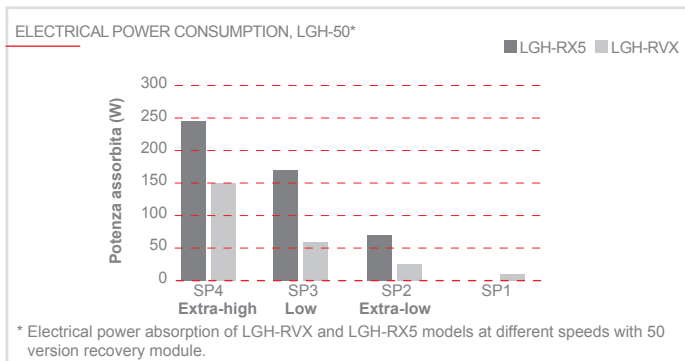

Bypass shutter

The LGH-RVX series is equipped with a bypass shutter:

When the shutter is open, fresh air is fed to the interior space with no heat recovery, passing through the filter only.

The bypass shutter may be activated manually from the remote control, or automatically in specific thermal conditions (Free-Cooling).

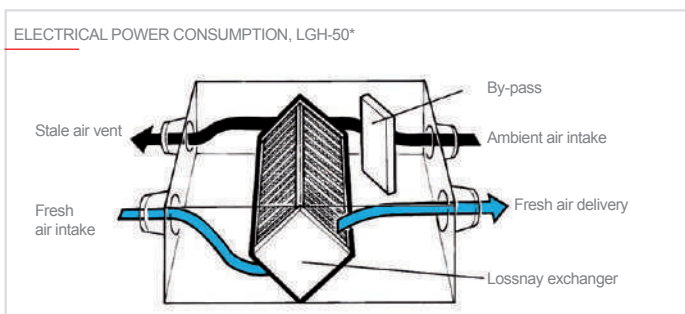

New PZ-62DR-E dedicated remote control

The new wired remote control unit specifically for LGH-RVX heat recovery units boasts a fresh new look and new features.

- Possibility of managing a group of up to 15 units
- Simple and intuitive
- Backlit LCD screen
- Internal weekly timer
- Custom ventilation strategies for mode switching (Auto/recovery/bypass)
- Night purge function for active night-time ventilation in summer.



Easy installation

High air volumes and low height.

Three new models with important innovations have supplemented the LGH enthalpic recuperators line.

The RVXT models treat high volumes of air (up to 250m³/h) and are extremely low in height (only 500mm), a feature that makes them exceptionally flexible during installation, especially where the height of the false ceiling does not allow the use of RVX models.

The RVXT models are also equipped with an enthalpy exchange package in treated paper and are fitted with "G3" filters as standard (Coarse 35% based on ISO 16890).

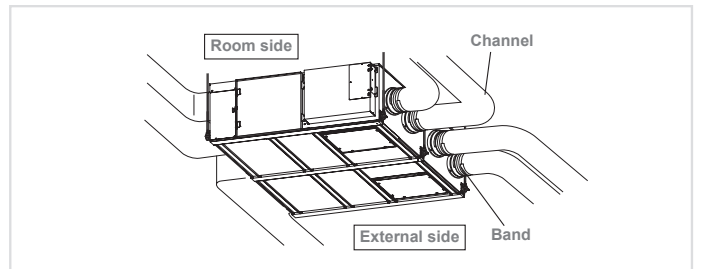

Technical specifications

MODEL		LGH-50RVX-E					
Power supply	V/Phase/Hz	220-240 / 1-phase /50					
Speed		SP4	SP3	SP2	SP1		
Current	A	1.15	0.59	0.26-0.27	0.13		
Power input	W	165-173	78-81	32-35	12-14		
Air volume	m³/h	500	375	250	125		
	L/s	138.9	104.2	69.4	34.7		
External static pressure	mmH ₂ O	12.24	6.93	3.06	0.82		
	Pa	120	68	30	8		
Temp. heat exch. Efficiency	%	78.0	81.0	83.5	87.0		
Total heat exch. Efficiency	Cooling	%	66.5	68.0	72.5	82.0	
	Heating	%	69.0	71.0	75.0	82.5	
Sound pressure level	dB(A)	34-35	28-29	19-20	18		
Duct qty x diameter	mm	4 x 200	4 x 200	4 x 200	4 x 200		
Wheight	kg	33	33	33	33		
Dimensions	HxLxD	mm	331x1016 x888	331x1016 x888	331x1016 x888	331x1016 x888	
	Outdoor temp.	°C	-10 ~ +40	-10 ~ +40	-10 ~ +40	-10 ~ +40	
Operating field*	Max outdoor RH	%	80	80	80	80	
	Max indoor temp	°C	40	40	40	40	
	Max indoor RH	%	80	80	80	80	
	Max indoor RH	%	80	80	80	80	

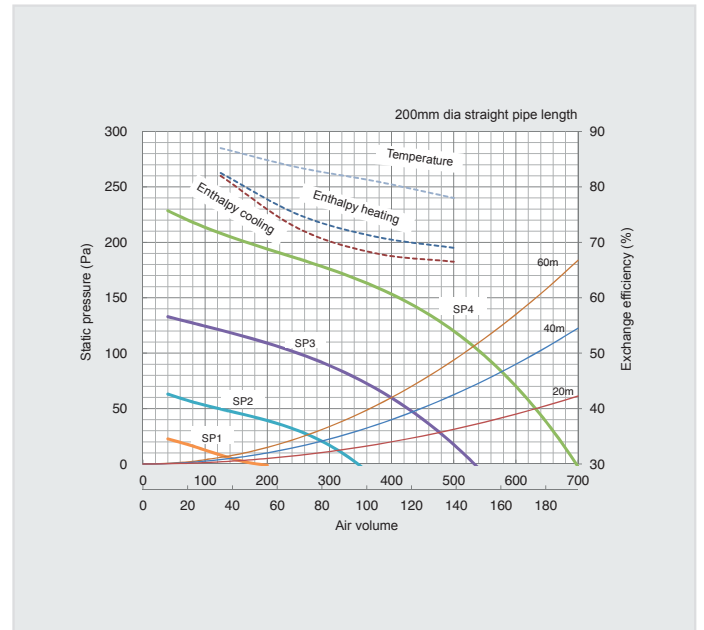

Technical specifications

MODEL		LGH-65RVX-E					
Power supply	V/Phase/Hz	220-240 / 1-phase /50					
Speed		SP4	SP3	SP2	SP1		
Current	A	65-1.72	0.90-0.86	0.39-0.38	0.15-0.16		
Power input	W	252-262	131	49-47	15-17		
Air volume	m³/h	650	488	325	163		
	L/s	180.6	135.4	90.3	45.1		
External static pressure	mmH ₂ O	12.24	6.93	3.06	0.82		
	Pa	120	68	30	8		
Temp. heat exch. Efficiency	%	77.0	81.0	84.0	86.0		
Total heat exch. Efficiency	Cooling	%	66.0	69.5	74.0	81.0	
	Heating	%	68.5	71.0	76.0	82.0	
Sound pressure level	dB(A)	34.5-35.5	29	22	18		
Duct qty x diameter	mm	4 x 200	4 x 200	4 x 200	4 x 200		
Wheight	kg	38	38	38	38		
Dimensions	HxLxD	mm	404x954 x908	404x954 x908	404x954 x908	404x954 x908	
	Outdoor temp.	°C	-10 ~ +40	-10 ~ +40	-10 ~ +40	-10 ~ +40	
Operating field*	Max outdoor RH	%	80	80	80	80	
	Max indoor temp	°C	40	40	40	40	
	Max indoor RH	%	80	80	80	80	
	Max indoor RH	%	80	80	80	80	

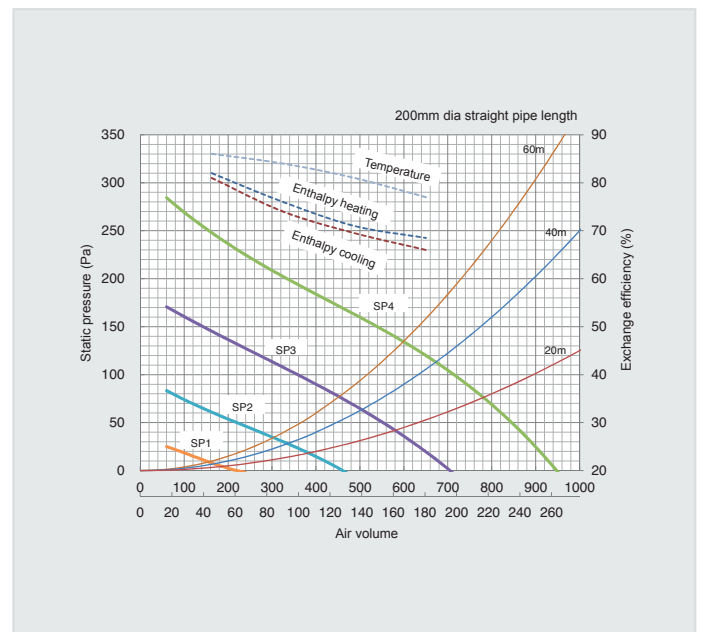

Technical specifications

MODEL		LGH-80RVX-E					
Power supply	V/Phase/Hz	220-240 / 1-phase /50					
Speed		SP4	SP3	SP2	SP1		
Current	A	1.82-1.97	0.83-0.86	0.36-0.40	0.15-0.16		
Power input	W	335-340	151	60-64	18-20		
Air volume	m³/h	800	600	400	200		
	L/s	222.2	166.7	111.1	55.6		
External static pressure	mmH ₂ O	15.30	8.67	3.82	1.02		
	Pa	150	85	37.5	10		
Temp. heat exch. Efficiency	%	79.0	82.5	84.0	85.0		
Total heat exch. Efficiency	Cooling	%	70.0	72.5	78.0	81.0	
	Heating	%	71.0	73.5	78.0	81.0	
Sound pressure level	dB(A)	34.5-36.0	30.0	23	18		
Duct qty x diameter	mm	4 x 250	4 x 250	4 x 250	4 x 250		
Wheight	kg	48	48	48	48		
Dimensions	HxLxD	mm	404x1004 x1144	404x1004 x1144	404x1004 x1144	404x1004 x1144	
	Outdoor temp.	°C	-10 ~ +40	-10 ~ +40	-10 ~ +40	-10 ~ +40	
Operating field*	Max outdoor RH	%	80	80	80	80	
	Max indoor temp	°C	40	40	40	40	
	Max indoor RH	%	80	80	80	80	
	Max indoor RH	%	80	80	80	80	

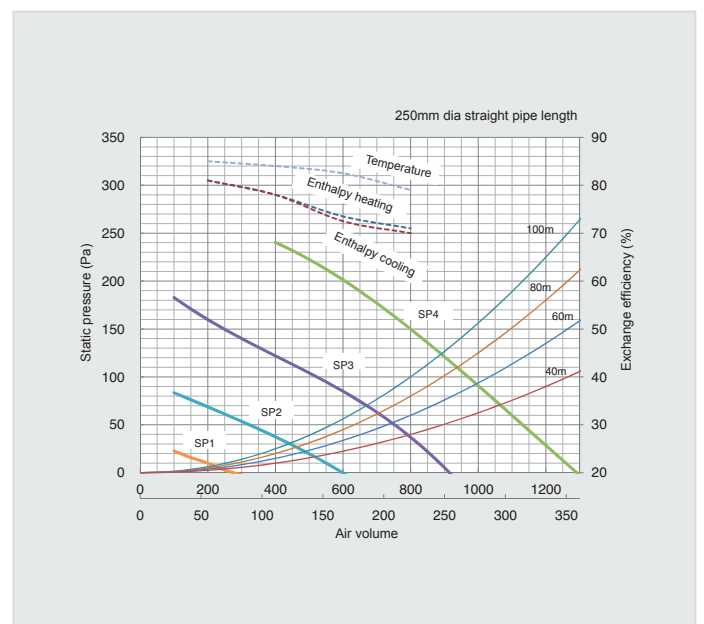

* In case of temperature < -10°C fan will work discontinuously. Lossnay controlled heat generator is recommended in this condition.

Technical specifications

MODEL		LGH-100RVX-E				
Power supply	V/Phase/Hz	220-240 / 1-phase /50				
Speed		SP4	SP3	SP2	SP1	
Current	A	2.50	1.20	0.50-0.51	0.17-0.19	
Power input	W	420	200	75	21	
Air volume	m³/h	1000	750	500	250	
	L/s	277.8	208.3	138.9	69.4	
External static pressure	mmH ₂ O	17.34	9.75	4.33	1.08	
	Pa	170	95.6	42.5	10.6	
Temp. heat exch. Efficiency	%	80.0	83.0	86.5	89.5	
Total heat exch. Efficiency	Cooling	%	71.0	73.0	77.0	85.5
	Heating	%	72.5	74.0	78.0	87.0
Sound pressure level	dB(A)	37-38	31-32	23-24	18	
Duct qty x diameter	mm	4 x 250	4 x 250	4 x 250	4 x 250	
Wheight	kg	54	54	54	54	
Dimensions	HxLxD	mm	404x1231 x1144	404x1231 x1144	404x1231 x1144	404x1231 x1144
	Operating field*	Outdoor temp. °C	-10 ~ +40	-10 ~ +40	-10 ~ +40	-10 ~ +40
Operating field*	Max outdoor RH	%	80	80	80	80
	Max indoor temp	°C	40	40	40	40
	Max indoor RH	%	80	80	80	80

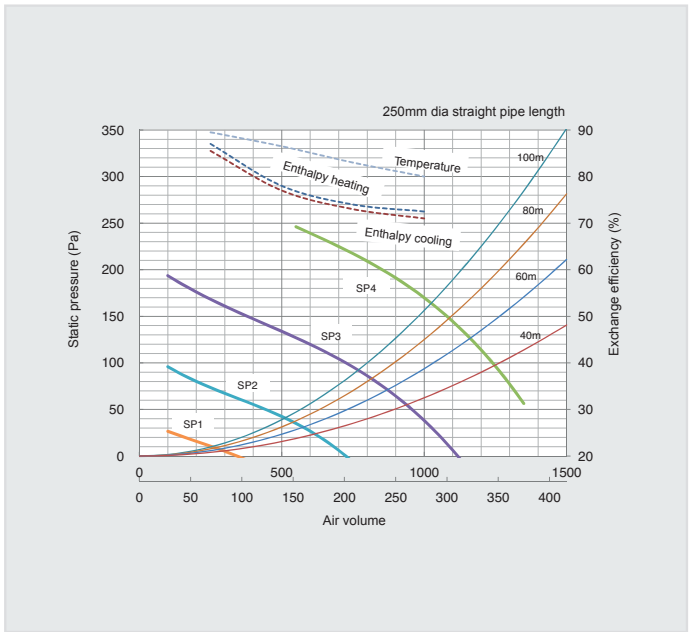

Technical specifications

MODEL		LGH-150RVX-E				
Power supply	V/Phase/Hz	220-240 / 1-phase /50				
Speed		SP4	SP3	SP2	SP1	
Current	A	3.71-3.85	1.75-1.78	0.70-0.78	0.29-0.30	
Power input	W	670-698	311	123-124	38-44	
Air volume	m³/h	1500	1125	750	375	
	L/s	416.7	312.5	208.3	104.2	
External static pressure	mmH ₂ O	17.85	10.03	4.47	1.11	
	Pa	175	98.4	43.8	10.9	
Temp. heat exch. Efficiency	%	80.0	82.5	84.0	85.0	
Total heat exch. Efficiency	Cooling	%	70.5	72.5	78.0	81.0
	Heating	%	72.0	73.5	78.0	81.0
Sound pressure level	dB(A)	39.0-40.5	32-33	24-26	18	
Duct qty x diameter	mm	4 x 250 / 2 x 4 x 250 / 2 x 4 x 250 / 2 x 4 x 250 / 2 x (270x700)				
Wheight	kg	98	98	98	98	
Dimensions	HxLxD	mm	808x1004x1144	808x1004x1144	808x1004x1144	808x1004x1144
	Operating field*	Outdoor temp. °C	-10 ~ +40	-10 ~ +40	-10 ~ +40	-10 ~ +40
Operating field*	Max outdoor RH	%	80	80	80	80
	Max indoor temp	°C	40	40	40	40
	Max indoor RH	%	80	80	80	80

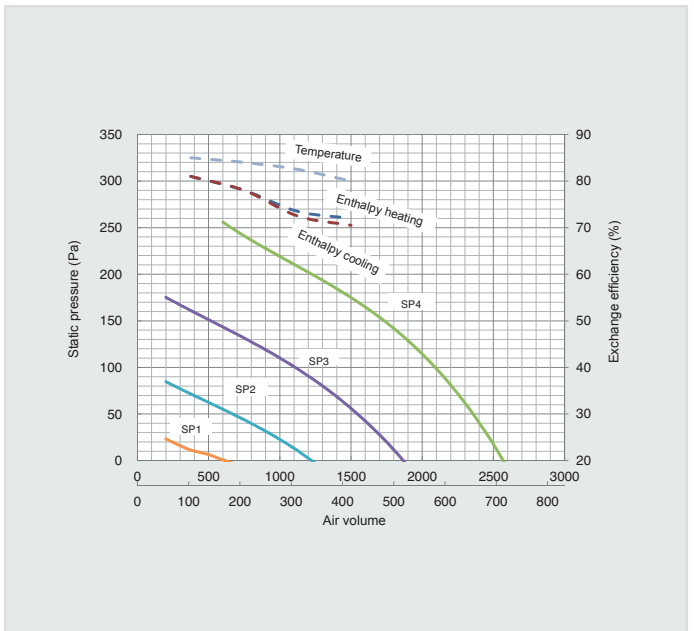

Technical specifications

MODEL		LGH-200RVX-E				
Power supply	V/Phase/Hz	220-240 / 1-phase /50				
Speed		SP4	SP3	SP2	SP1	
Current	A	4.88-4.54	2.20-2.06	0.88-0.87	0.33-0.35	
Power input	W	850-853	400-372	153-150	42-49	
Air volume	m³/h	2000	1500	1000	500	
	L/s	555.6	416.7	277.8	138.9	
External static pressure	mmH ₂ O	15.30	8.61	3.82	0.97	
	Pa	150	84.4	37.5	9.5	
Temp. heat exch. Efficiency	%	80.0	83.0	86.5	89.5	
Total heat exch. Efficiency	Cooling	%	71.0	73.0	77.0	85.5
	Heating	%	72.5	74.0	78.0	87.0
Sound pressure level	dB(A)	40-41	40-41	40-41	40-41	
Duct qty x diameter	mm	4 x 250 / 2 x 4 x 250 / 2 x 4 x 250 / 2 x 4 x 250 / 2 x (270x700)				
Wheight	kg	110	110	110	110	
Dimensions	HxLxD	mm	808x1231 x1144	808x1231 x1144	808x1231 x1144	808x1231 x1144
	Operating field*	Outdoor temp. °C	-10 ~ +40	-10 ~ +40	-10 ~ +40	-10 ~ +40
Operating field*	Max outdoor RH	%	80	80	80	80
	Max indoor temp	°C	40	40	40	40
	Max indoor RH	%	80	80	80	80

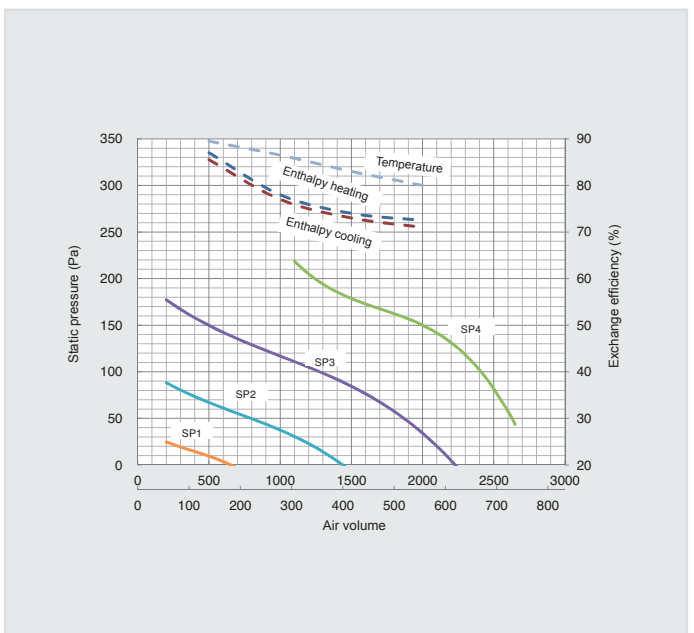

* In case of temperature < -10°C fan will work discontinuously. Lossnay controlled heat generator is recommended in this condition.

Technical specifications

MODEL		LGH-150RVXT-E				
Power supply	V/Phase/Hz	220-240 / 1-phase /50				
Speed		SP4	SP3	SP2	SP1	
Current	A	4.30 - 3.40	2.40 - 1.80	1.10 - 0.77	0.36 - 0.31	
Power input	W	792 - 625	421 - 334	176 - 134	48 - 37	
Air volume	m³/h	1500	1125	750	375	
	L/s	417	313	208	104	
External static pressure	mmH ₂ O	175	98	44	11	
	Pa	100	56	25	6	
Temp. heat exch. Efficiency	%	80.0	80.5	81.0	81.5	
Total heat exch. Efficiency	Cooling	%	69.0	70.0	72.0	74.0
	Heating	%	70.0	71.0	73.0	75.0
Sound pressure level	dB(A)	39.5	35.5	29.5	22.0	
Duct qty x diameter	mm	4 x 250 / 2 x 4 x 250 / 2 x 4 x 250 / 2 x 4 x 250 / 2 x (250x750) (250x750) (250x750) (250x750)				
Wheight	kg	156	156	156	156	
Dimensions	HxLxD	mm	500 x 1980 x 1500	500 x 1980 x 1500	500 x 1980 x 1500	500 x 1980 x 1500
	Operating field*	Outdoor temp. °C	-10 ~ +40	-10 ~ +40	-10 ~ +40	-10 ~ +40
		Max outdoor RH %	80	80	80	80
		Max indoor temp °C	40	40	40	40
		Max indoor RH %	80	80	80	80

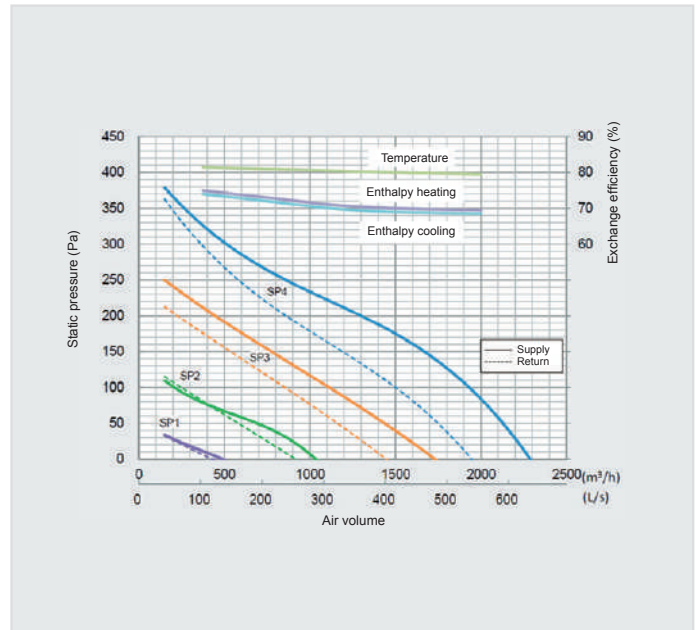

Technical specifications

MODEL		LGH-200RVXT-E				
Power supply	V/Phase/Hz	220-240 / 1-phase /50				
Speed		SP4	SP3	SP2	SP1	
Current	A	5.40 - 5.00	2.70 - 2.20	1.10 - 0.85	0.39 - 0.34	
Power input	W	1000 - 916	494 - 407	197 - 150	56 - 45	
Air volume	m³/h	2000	1500	1000	500	
	L/s	556	417	278	139	
External static pressure	mmH ₂ O	175	98	44	11	
	Pa	100	56	25	6	
Temp. heat exch. Efficiency	%	80.0	81.0	82.5	84.0	
Total heat exch. Efficiency	Cooling	%	70.0	71.0	74.5	80.5
	Heating	%	72.5	73.5	77.0	83.0
Sound pressure level	dB(A)	39.5	35.5	28.0	22.0	
Duct qty x diameter	mm	4 x 250 / 2 x 4 x 250 / 2 x 4 x 250 / 2 x 4 x 250 / 2 x (250x750) (250x750) (250x750) (250x750)				
Wheight	kg	159	159	159	159	
Dimensions	HxLxD	mm	500 x 1980 x 1500	500 x 1980 x 1500	500 x 1980 x 1500	500 x 1980 x 1500
	Operating field*	Outdoor temp. °C	-10 ~ +40	-10 ~ +40	-10 ~ +40	-10 ~ +40
		Max outdoor RH %	80	80	80	80
		Max indoor temp °C	40	40	40	40
		Max indoor RH %	80	80	80	80

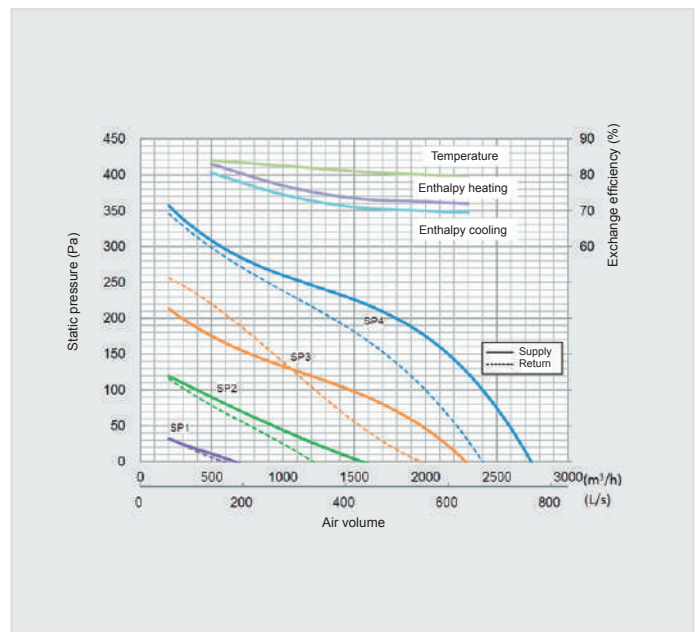

Technical specifications

MODEL		LGH-250RVXT-E				
Power supply	V/Phase/Hz	220-240 / 1-phase /50				
Speed		SP4	SP3	SP2	SP1	
Current	A	7.60 - 6.90	3.60 - 3.10	1.40 - 1.30	0.57 - 0.49	
Power input	W	1446 - 1298	687 - 587	244 - 212	82 - 69	
Air volume	m³/h	2500	1875	1250	625	
	L/s	694	521	347	174	
External static pressure	mmH ₂ O	175	98	44	11	
	Pa	100	56	25	6	
Temp. heat exch. Efficiency	%	77.0	79.0	80.5	82.5	
Total heat exch. Efficiency	Cooling	%	65.5	69.0	71.5	76.5
	Heating	%	68.0	71.5	74.0	79.0
Sound pressure level	dB(A)	43.0	39.0	32.0	24.0	
Duct qty x diameter	mm	4 x 250 / 2 x 4 x 250 / 2 x 4 x 250 / 2 x 4 x 250 / 2 x (250x750) (250x750) (250x750) (250x750)				
Wheight	kg	198	198	198	198	
Dimensions	HxLxD	mm	500 x 1980 x 1500	500 x 1980 x 1500	500 x 1980 x 1500	500 x 1980 x 1500
	Operating field*	Outdoor temp. °C	-10 ~ +40	-10 ~ +40	-10 ~ +40	-10 ~ +40
		Max outdoor RH %	80	80	80	80
		Max indoor temp °C	40	40	40	40
		Max indoor RH %	80	80	80	80

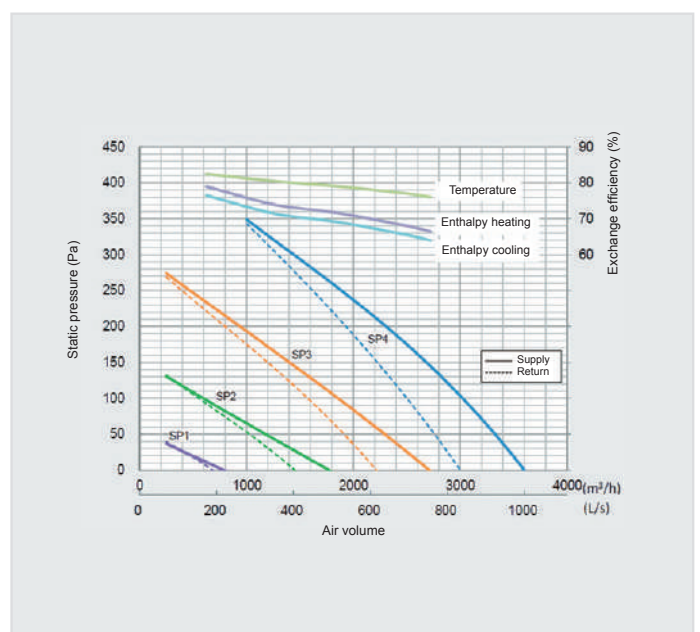

* In case of temperature < -10°C fan will work discontinuously. Lossnay controlled heat generator is recommended in this condition.