

PEFY-P VMS1-E

INDOOR UNITS - Ceiling concealed medium to low static pressure

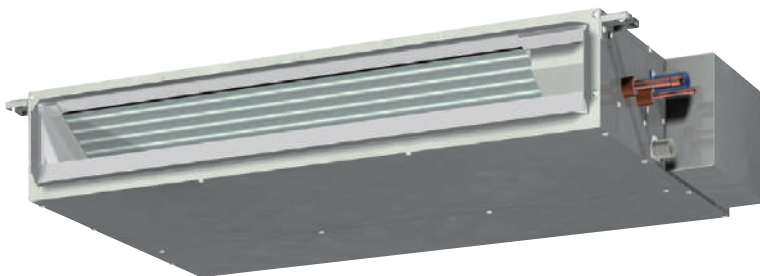

CITY MULTI

Ideal for...

This **ultra-slim 200 mm** unit offers extraordinary flexibility and is particularly suitable for use in rooms where low noise and compact vertical dimensions are essential.

Ultra-slim

These units are extremely thin, at just 200 mm in height.

Extremely compact width and lengths of:

7790 mm for P15 and P32 models

990 mm for P40 and P50 models

1190 mm for P63 models

May be installed easily in cramped spaces such as ceiling recesses or double ceilings.

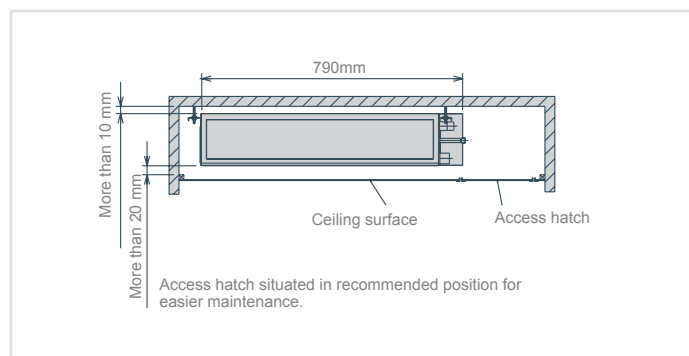

Condensate lift pump

The VMS1 is equipped with a condensate lift pump as standard.

Adjustable static pressure

L'unità è adatta per diverse applicazioni, grazie alle sue 4 impostazioni di presWith 4 selectable static pressure settings (5, 15, 25 and 50Pa), this unit is ideal for a variety of different applications.

Adjustable air flow

Three different fan speed settings - "low", "medium" and "high" – ensure the desired levels of comfort.

Low noise

The new design of the centrifugal fan and coil reduces noise levels.

Noise level

dB(A)

Capacity		P15	P20	P25	P32	P40	P50	P63
Fan speed	High		28		32	33	35	36
	Medium		24		27	30	32	33
	Low		22		24	28	30	30



Key Technologies

Technical specifications

MODEL		PEFY-P15VMS1-E	PEFY-P20VMS1-E	PEFY-P25VMS1-E	PEFY-P32VMS1-E	PEFY-P40VMS1-E	PEFY-P50VMS1-E	PEFY-P63VMS1-E	
Power		A single-phase, 220-240V 50Hz / a 1 fase, 220-240V 60Hz							
Capacity in cooling mode*1	kW	1.7	2.2	2.8	3.6	4.5	5.6	7.1	
	Btu/h	5800	7500	9600	12300	15400	19100	24200	
Capacity in heating mode*1	kW	1.9	2.5	3.2	4.0	5.0	6.3	8.0	
	Btu/h	6500	8500	10900	13600	17100	21500	27300	
Power consumption	Cooling kW	0.05 [0.03]	0.05 [0.03]	0.06 [0.04]	0.07 [0.05]	0.07 [0.05]	0.09 [0.07]	0.09 [0.07]	
	Heating kW	0.03 [0.03]	0.03 [0.03]	0.04 [0.04]	0.05 [0.05]	0.05 [0.05]	0.07 [0.07]	0.07 [0.07]	
Current	Cooling A	0.42 [0.31]	0.47 [0.36]	0.50 [0.39]	0.50 [0.39]	0.56 [0.45]	0.67 [0.56]	0.72 [0.61]	
	Heating A	0.31 [0.31]	0.36 [0.36]	0.39 [0.39]	0.39 [0.39]	0.45 [0.45]	0.56 [0.56]	0.61 [0.61]	
External finish		Galvanised							
Dimensions HxLxW		mm	200x790x700	200x790x700	200x790x700	200x790x700	200x990x700	200x990x700	200x1190x700
Net weight		kg	19 [18]	19 [18]	19 [18]	20 [19]	24 [23]	24 [23]	28 [27]
Heat exchanger		Cross fins (sheet aluminium fins and copper piping)							
Fan	Type x Quantity	Sirocco x 2			Sirocco x 3			Sirocco x 4	
	Air flow (low-medium-high) m³/min	5-6-7	5.5-6.5-8	5.5-7-9	6-8-10	8-9.5-11	9.5-11-13	12-14-16.5	
	Static external press Pa	5-15-35-50	5-15-35-50	5-15-35-50	5-15-35-50	5-15-35-50	5-15-35-50	5-15-35-50	
Motor	Type	Brushless DC motor							
	Power output kW	0.096	0.096	0.096	0.096	0.096	0.096	0.096	
Air filter		Polypropylene honeycomb fabric (washable)							
Refrigerant pipe diameter	Gas (swaged) mm	ø12.7 brazed	ø12.7 brazed	ø12.7 brazed	ø12.7 brazed	ø12.7 brazed	ø12.7 brazed	ø15.88 brazed	
	Liquid (swaged) mm	ø6.35 brazed	ø6.35 brazed	ø6.35 brazed	ø6.35 brazed	ø6.35 brazed	ø6.35 brazed	ø9.52 brazed	
Local drain pipe diameter		O.D. 32	O.D. 32	O.D. 32	O.D. 32	O.D. 32	O.D. 32	O.D. 32	
Sound pressure (low-medium-high) dB(A)		22-24-28	23-25-29	24-26-30	24-27-32	28-30-33	30-32-35	30-33-36	

*1 For heating/cooling capacity, the maximum value with the unit operating in the following conditions is given.
 Cooling: indoor 27°C DB/19°C WB, outdoor 35°C DB.
 Heating: indoor 20°C DB (68°F DB), outdoor 7°C DB (45°F DB/43°F WB). Pipe length: 7.5 m (24-9/16 feet).
 Height difference: 0 m (0 feet).

*2 Static external pressure is set to 15 Pa by default.

*3 [] in case of PEFY-P15-63VMS1L-E.